

# Inductive displacement sensor

Series  
**SM40**

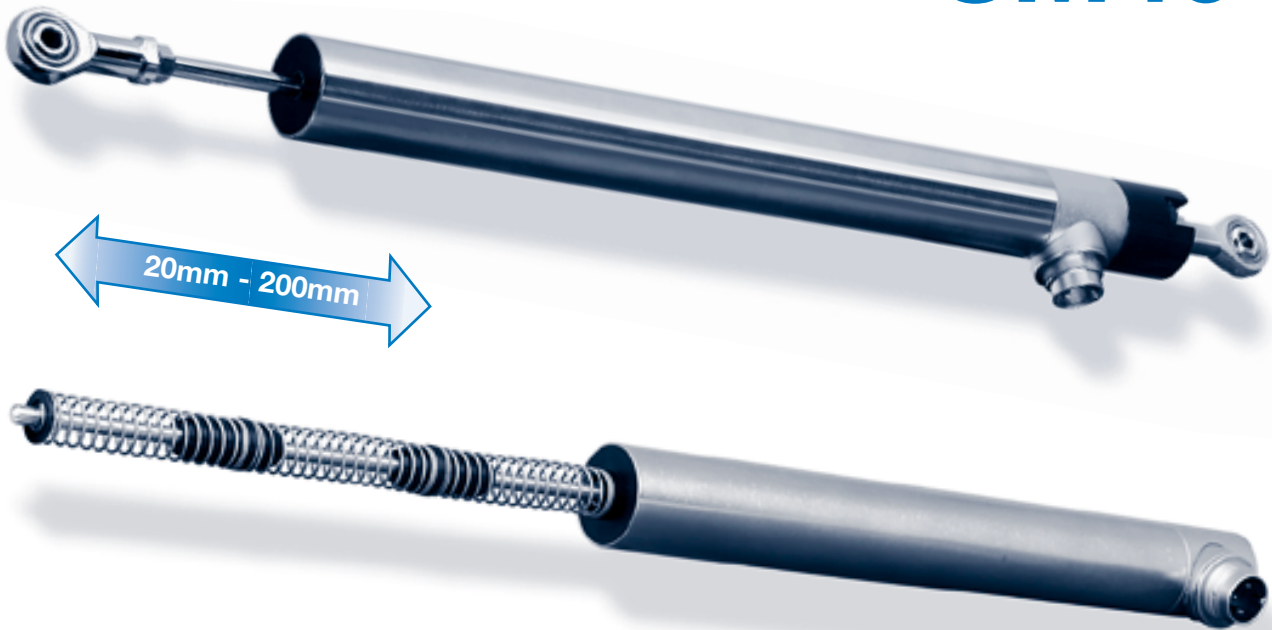

#### Standard measuring stroke:

20mm	40mm	70mm	100mm	150mm	200mm
------	------	------	-------	-------	-------

#### Standard designs

Type	Output	Supply voltage $U_B^*$	Signal**	Centre
SM401	0 .. 20 mA	20 .. 32 V	increasing	10 mA
SM402			decreasing	
SM403	4 .. 20 mA	20 .. 32 V	increasing	12 mA
SM404			decreasing	
SM405	$\pm 10$ V	$\pm 13$ .. $\pm 16$ V	increasing	0 V
SM406			decreasing	
SM407	0..10 V	20 .. 32 V	increasing	5 V
SM408			decreasing	

\* reverse battery protection

\*\*Increasing signifies increasing output signal when the plunger is moved towards the plug.

#### Technical data:

Accuracy	< 0,5% or 0,25%
Temperature drift	< 0,01% / °C
Cutoff frequency	800 Hz
Temperature range	-20°C to +85°C
Resistance to shocks	250g SRS 20-2000Hz
Resistance to vibration	20g rms (50g peak)
Protection class	IP66*

\* with screwed-on matching opposite plug BI423

- universally usable displacement sensor
- measuring stroke up to 200mm
- housing diameter 25mm
- integrated electronics
- also as gauge type with return spring
- system protection IP66
- accuracy 0.5% or 0.25%

#### Structure and function:

Inside a coil a NiFe core is moved axially. The position of the core in each case causes corresponding inductivity distribution in the two coil halves, which is converted into a stroke-proportional signal by an integrated electronics system.

## SM40 Standard

### Dimensions and mass:

Measuring stroke mm	L1 mm	L2 mm	Sensor	Plunger
20	40	110	210g	15g
40	50	140	240g	19g
70	65	200	310g	25g
100	80	250	380g	31g
150	105	350	520g	41g
200	130	500	720g	56g

L1 = Plunger in central position

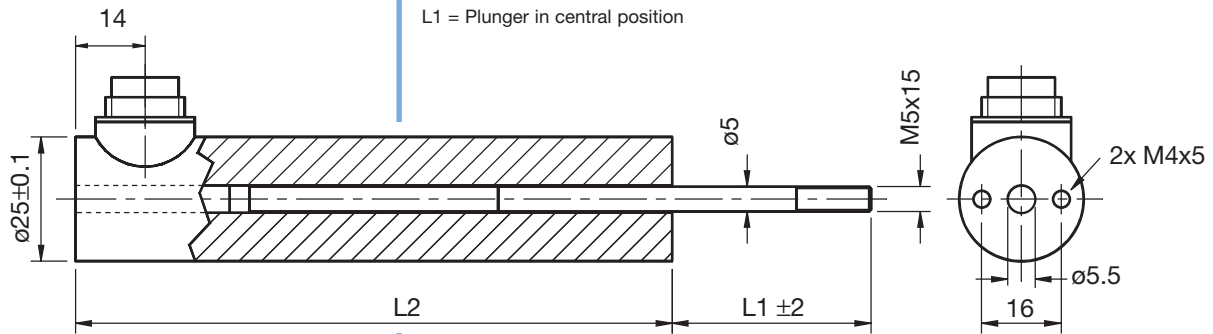

## SM40 .T

### Dimensions and spring force:

Measuring stroke mm	BM mm	B1 mm	L2 mm	Fm N	Fc N/mm
20	70	85	110	~4	0,07
40	70	98	140	~4	0,07
70	110	160	200	~4	0,05
100	140	195	250	~4	0,03

BM = plunger in central position, B1 = plunger fully extended,  
Fm = spring force in central position, Fc = spring rate

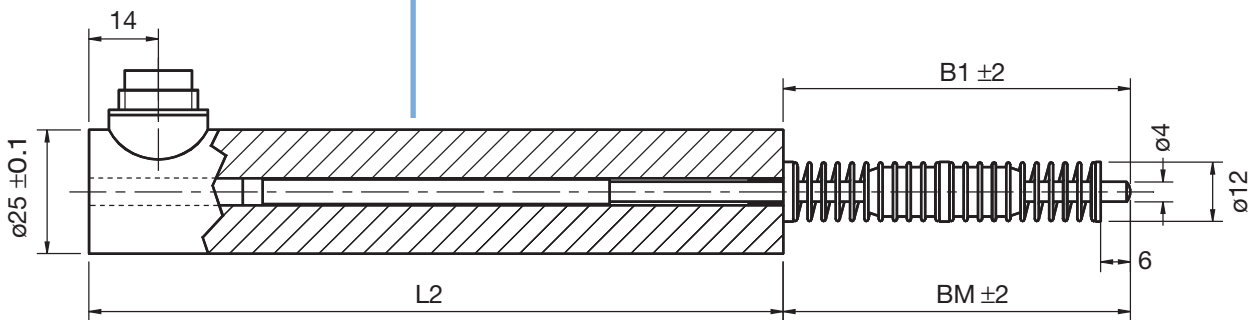

**SM40 .FGH** with two ball joints  
M5, plunger (5mm dia.) guided in  
brass bush and captive.

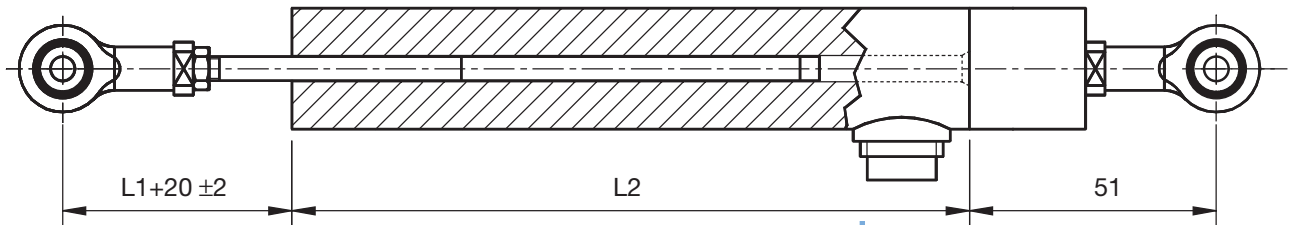

**SM40 .Kx** (x is cable length in  
meters) with Pg9 screw connection and  
oil-resistant shielded 0.56mm<sup>2</sup> cable

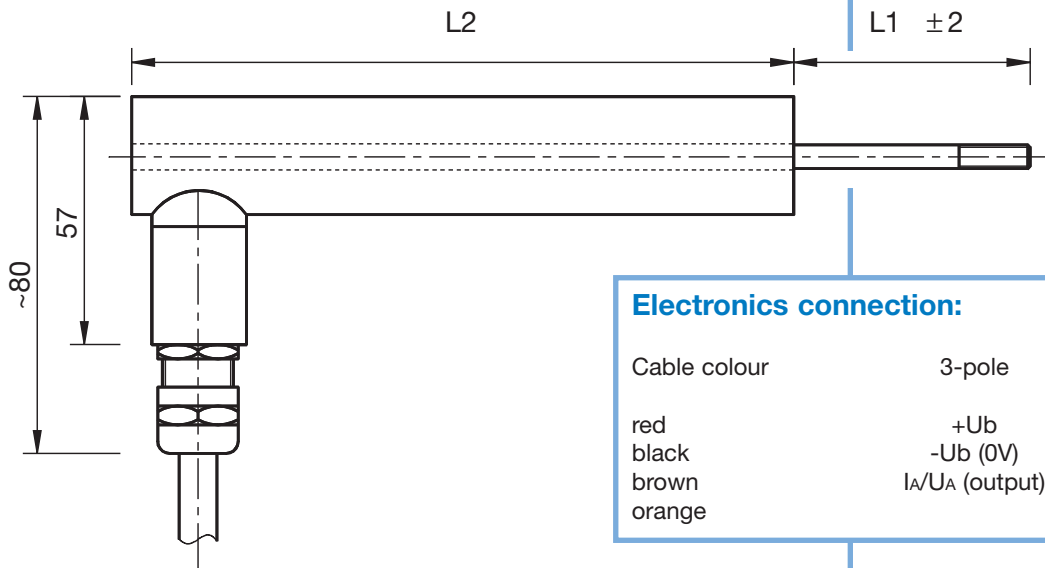

### Electronics connection:

Cable colour	3-pole	4-pole
red	+Ub	+Ub
black	-Ub (0V)	-Ub
brown	I <sub>A</sub> /U <sub>A</sub> (output)	U <sub>A</sub> (output)
orange		0V

### Assembly clamps

#### SM906.400

Brass, nickel-plated

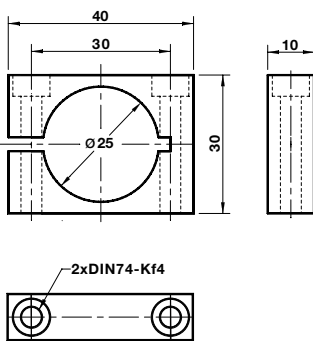

(incl.2 fastening screws  
M4x35 DIN912 VA)

#### SM906.401

Polypropylene

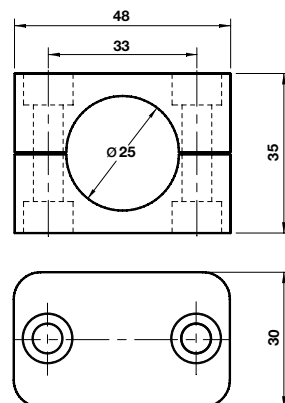

(incl.2 fastening screws  
M6x35 DIN912 VA)

### Other versions:

- extended measuring stroke  
+ 10mm (0.25%) or  
+15mm(0.5%) possible  
(special calibration)
- other measuring strokes for  
standard equipment (special  
calibration)
- temperature range to 100°C  
with Kynar connecting wires  
AWG 20
- gauge with measuring roll
- 2 ball joints and rubber-metal  
vibration protection
- 4mm dia. plunger guided in  
teflon bush
- other supply voltages and  
outputs (analog and digital)

## Electrical connections

(plug part viewed on measuring data sensor)

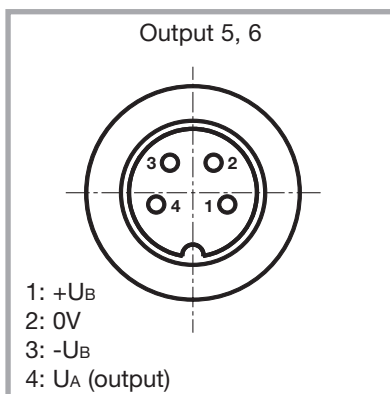
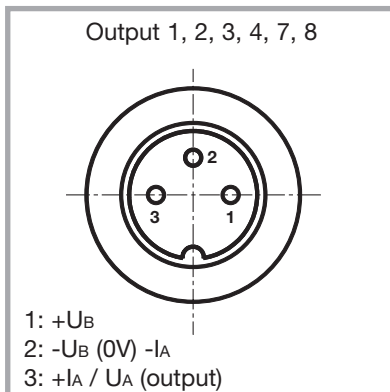

### Opposite matching plug: (to be ordered separately)

#### IP40:

Plug ser. 681 3- or 4-pole metal housing with rubber grommet

#### IP66:

Plug ser. 423 3- or 4-pole metal housing with ground slip ring

### Current output (SM401..404)

Output signal	0..20 mA or 4..20 mA
Operating current I <sub>B</sub>	max. 60 mA
Working resistance R <sub>L</sub>	0..500Ω
Residual ripple	< 0,005 mA <sub>pp</sub>
Dependent on R <sub>L</sub>	< 0,001% for ΔR <sub>L</sub> = 100Ω
Dependent on U <sub>B</sub>	< 0,05% for ΔU <sub>B</sub> = 1V

### Voltage output (SM405..408)

Output signal	±10 VDC or 0..10 VDC
Operating current I <sub>B</sub>	max. 50 mA
Permissible load R <sub>L</sub>	≥ 2 kΩ (short-circuit proof)
Residual ripple	< 5 mV <sub>pp</sub>
Residual voltage SM407/408	max. 0,1 VDC
Dependent on U <sub>B</sub>	< 0,05% for ΔU <sub>B</sub> = 1V

Note : Unless otherwise stated, the data given are for 20°C ambient temperature and 24V DC or ±15V DC supply voltage U<sub>B</sub> after 10 minute switching on period.

### Material:

Outer and inner tube	stainless steel, rust-free
Plunger	stainless steel, rust-free
Core	NiFe alloy, rust-free
Plug housing	brass, nickel-plated
Contacts	brass, gold-plated
Spring	spring-steel, rust-free

### Special versions and accessories:

Version D	Delrin plunger guide
Version F	plunger guided and captive
Version G	ball joint on plunger
Version H	ball joint on housing
Version K	cable outlet
Version T	gauge
SM906.400	assembly clamp brass nickel-plated
SM906.401	assembly clamp polypropylene

## Ordering designation

SM40 3 . 40 . 2 . T

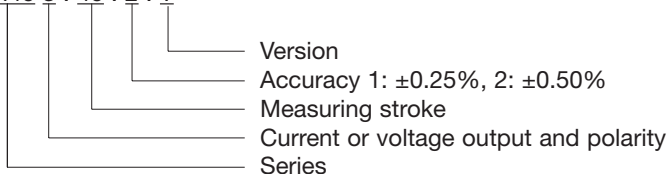

Ordering designations for customer-specific versions will be allotted by the factory.

e.g.: SM403.40.2.T

Gauge series 40, output 4-20mA (increasing),  
40mm measuring stroke, accuracy 0.5%

## Your business partner:



a.b.jödden gmbh  
Europark Fichtenhain A 13a  
47807 Krefeld, Germany  
Phone +49 2151 516259 0  
Fax +49 2151 516259 20  
info@abjoedden.de  
www.abjoedden.de